

# Remote Patient Monitoring System For Covid-19 Patient Using Wi-Fi-Based Pulse Oximeter Reading Sensor

Muhammad Akmal Mohd Taqayuddin<sup>1</sup>, Iman Hazwam Abd Halim<sup>2\*</sup>,  
Tajul Rosli Razak<sup>3</sup>, Mohd. Faris Mohd Fuzi<sup>4</sup>

<sup>1,2,3,4</sup>Faculty of Computer and Mathematical Science, Universiti Teknologi MARA Perlis Branch, Arau Campus,  
Malaysia

Corresponding author: \*hazwam688@uitm.edu.my

Received Date: 4 July 2022

Accepted Date: 15 July 2022

Revised Date: 20 August 2022

Published Date: 1 September 2022

---

## HIGHLIGHTS

- COVID-19 is coronavirus disease caused by the SARS-CoV-2 virus.
- The monitoring system is a method that can be used to update the Heart rate and Oxygen level status persistently.
- Pulse Oximeter sensor is noninvasively measuring the oxygen saturation of a blood and heart rate patient.
- A web server is a software and hardware that uses HTTP and other protocols to respond to client requests made over the World Wide Web.

---

## ABSTRACT

Continuous Heart disease and blood pressure are diseases that demand immediate care. Heart disease is currently one of the world's most fatal illnesses, as it always results in death. Pulse Oximeter Reading must be continuously measured, analyzed, and monitored in real-time to ensure that relevant measures may be taken when necessary. In this paper, we present a model that employs IoT to inform users about the incidence of heart disease and high blood pressure in their daily health. The Remote Patient Monitoring System for Covid-19 Patients Based on Oximeter Reading Sensor uses the Web Server ESP32 MAX30100 to replace the present Oximeter Reading monitoring and public broadcasting approaches. In addition, the NodeMCU ESP8266 Wi-Fi module allows the devices to save data in the cloud when connected to the Internet. Also, it is possible to construct effective real-time Heart Rate and Oxygen Level (IoT) monitoring. The findings indicated that users might access and monitor Heart rate and oxygen level via the Web Server regardless of their location in the monitoring region. Furthermore, providing an LCD is incredibly beneficial as it can show readings and ensure the users receive Pulse Oximeter Reading monitoring information when the device is in operation.

**Keywords:** Covid-19, Internet of Things (IoT), Monitoring system, NodeMCU, Pulse Oximeter Reading sensor.



## INTRODUCTION

Healthcare ICT (Information and Communication Technology) systems may communicate with medical equipment and software through the Internet of Medical Things (IoMT), a collection of internet networks (Marathe et al., 2019). Using digital technology, remote patient monitoring, also known as remote physiologic monitoring, transmits patient medical and health data electronically to healthcare practitioners for evaluation and, if required, suggestions and instructions known as remotely physiologic monitoring (Malasinghe et al., 2019). Red blood cell percentage and oxygen saturation may be measured using an oximeter, which provides a reading known as an "Oximeter Reading" (Kadhim et al., 2020). Pulse Oximeters are becoming significant in the medical field as many people suffer from heart problems, high cholesterol, and low blood sugar during this year's covid-19 (Jayaysingh et al., 2020).

COVID-19 sufferers might experience "Happy hypoxia", in which their oxygen levels are deficient, yet they otherwise look healthy. Because these individuals may be more seriously unwell than they realized, they should require additional treatment in a medical context, which is quite worrisome. Heart illness, high blood pressure, and low blood pressure are also severe throughout this Covid-19 worrisome (Dhont et al., 2020). A reliable measurement from the oximeter can only be obtained using one finger to measure heart rates (Patil et al., 2021). Many parts of the data life cycle for the Remote Monitoring System might be outsourced to other parties, which increases the danger of patients having their personal information hijacked (Pronovost et al., 2022). Hospitals have similar difficulties since they run the danger of implementing the following system that is vulnerable to attack, compromising the safety and privacy of their patients. Because of this, that must be secured enough to fulfil healthcare requirements. Although the degree of error may be minor and not clinically significant in many circumstances, it is possible that an erroneous measurement can lead to low blood oxygen levels that are not noticed. Pulse oximetry has several limitations, and it is vital to know how accuracy is computed and interpreted (Lee et al., 2022).

Previous work on Pulse rate monitoring systems was using pulse rate sensors, piezoelectric sensors and NodeMCU was published by (Patil et al., 2021). A pulse rate monitoring system using the Internet of Things is suggested at the core of the system. In addition to hospitals, this concept may also be utilized in residential areas to monitor patients. Data may be measured with or without a network, through the Internet. In this development's findings, heart rate is measured and recorded using a human finger. Using a piezoelectric sensor, a person's resonance frequency may be measured.

Another previous study was proposed by (Jayaysingh et al., 2020) that suggests using NodeMCU in an IoT-based patient monitoring system. There is a link between the patient monitoring program and the Internet of Things (IoT). Connected devices and the Internet's infrastructure are just the beginning of IoT technology (IoT). This model uses a pulse sensor to calculate the heart rate using the NodeMCU. A similar microcontroller, NodeMCU, may link IoT devices to the Internet. This project uses ThingSpeak as a cloud service for storing and analyzing data in real-time from mobile devices. This project aims to efficiently gather and transmit data from various sources (clients) to destinations (e.g., a database).

## METHODOLOGY

The Pulse Oximeter monitoring system based on a Wi-Fi network was adapted in this project. The first phase methodology of this study will start by explaining the general architecture of the proposed project, followed by elaboration of the prototype's circuit diagram for the second phase. At the last phase, the design scenario for the testing phase will be explained.

### General Architecture of the Proposed Project



Figure 1 shows the general architecture of the system. This project was developed to monitor pulse rate and Oxygen level in real-time. The oxygen level and pulse rate were measured by using a sensor connected to a microcontroller. The prototype architecture that takes data from sensors was sent to the NodeMCU to be analyzed. The NodeMCU with built-in Wi-Fi and Bluetooth was connected to the access point that has been configured to connect to the Internet. The following process was continued and then the message was sent to a Web Server Display Dashboard, which the result will be shown through the webserver when accessing it using the private host IP (Internet Protocol) Address. Users then could easily monitor heart rate and oxygen level status using the Webserver on the phone or the laptop just by typing the Ip address that appears at the LCD Display through the devices.

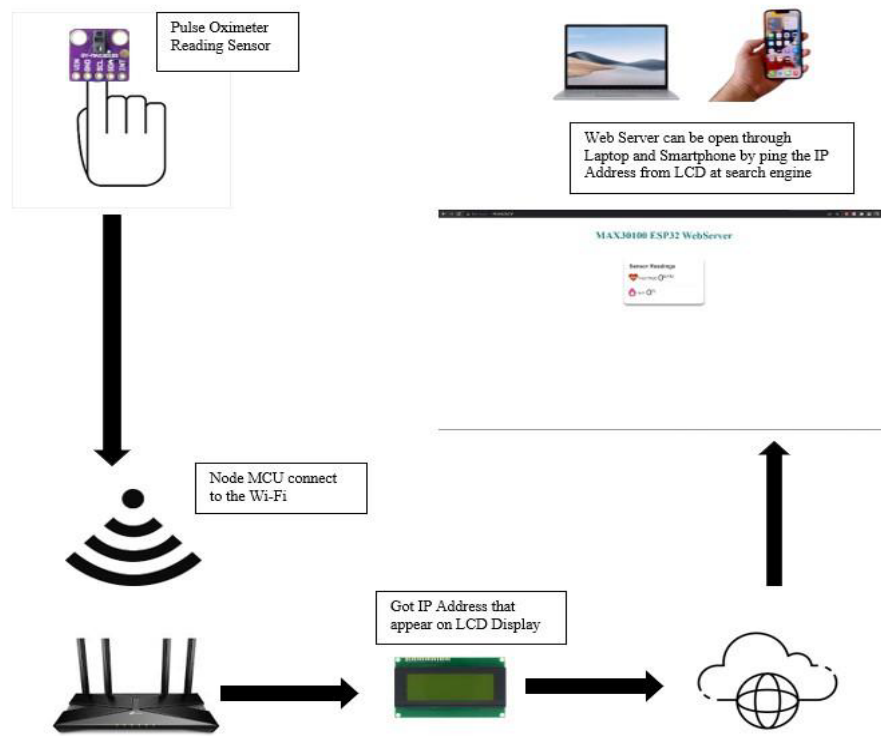

**Figure 1:** Pulse Oximeter monitoring system based on Wi-Fi network architecture

The pulse oximeter reading sensor connected to the microcontroller measured heart rate and oxygen level. The pulse oximeter sensor combines two LEDs (light emitting diodes), a photodetector, optimized optics, and low-noise analogue signal processing to detect pulse oximetry and heart rate signals. The duration from transmitting and receiving heart rate and oxygen level will be used to measure the network testing. NodeMCU will perform calculations, and if the heart rate and oxygen level are successfully read, the result will be sent to the user.

### Circuit Diagram of the Proposed Device



Figure 2 shows the circuit diagram for the proposed prototype device. Measuring and collecting data of user's Pulse rate (BPM) and Oxygen level (SpO2) is done by using MAX30100 Pulse Oximeter sensor. The collected data will be transferred to the microcontroller (NodeMCU ESP8266 v2) from the sensor through INT pin to pin D0 of NodeMCU before transmitting the data through its built-in Wi-Fi transmitter to the system's display dashboard on any mobile device. Both voltage power needed by the sensor and microcontroller are supplied by the breadboard power supply.

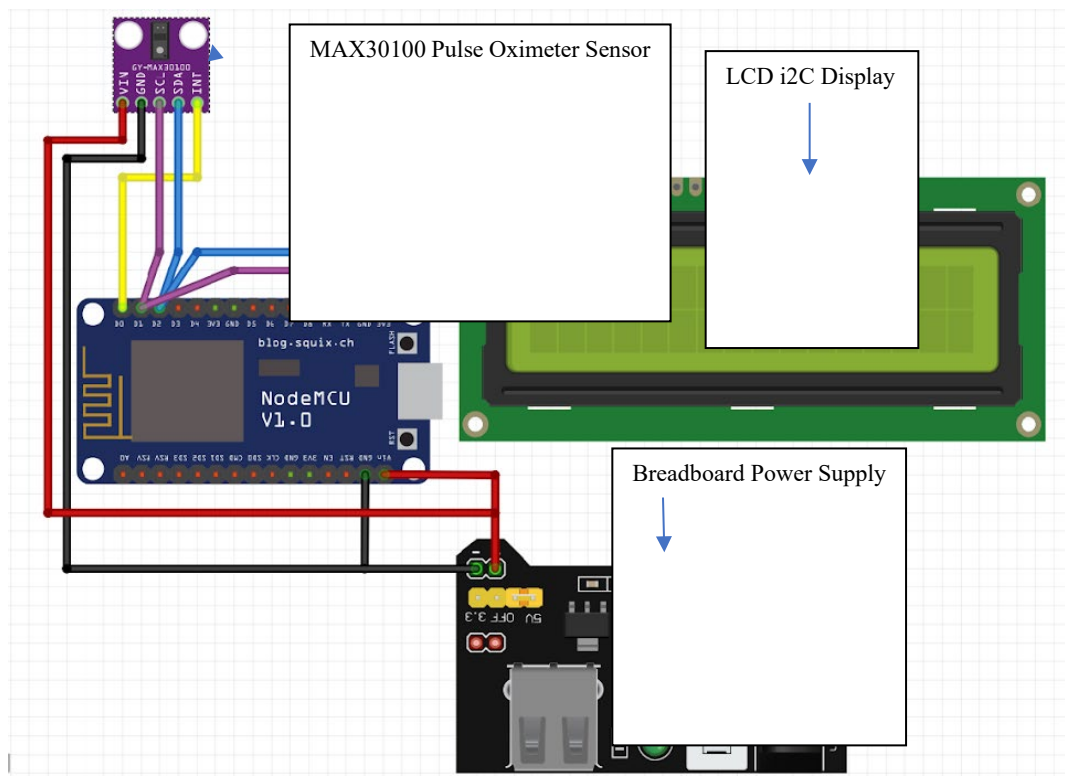

**Figure 2:** Circuit diagram for the proposed prototype

For reading the measurement from the device, LCD i2C display was used. The display of the pulse and oxygen reading was fetched from the NodeMCU through pin D2 of microcontroller to SDA pin of LCD. Sample of the reading can be referred to figure 3 that shows the actual assembly of the proposed prototype. User's finger needs to be placed on the sensor to read their pulse and oxygen level.



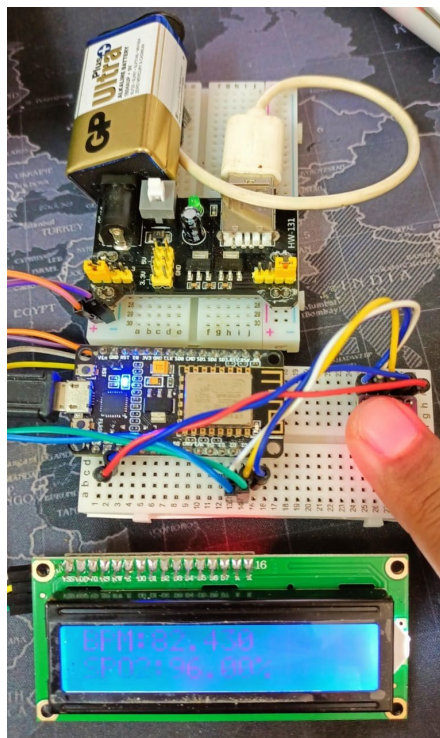

**Figure 3:** Prototype Assembly of proposed Oximeter Reading Monitoring System.

For the source code, Arduino IDE software was used as a platform to write the code and upload the code to the microcontroller. The embedded code will process the collected data and generate a Webserver as shown in figure 4 that will work as a display dashboard for displaying the pulse rate and oxygen level status which can be accessed from a smartphone or computer.

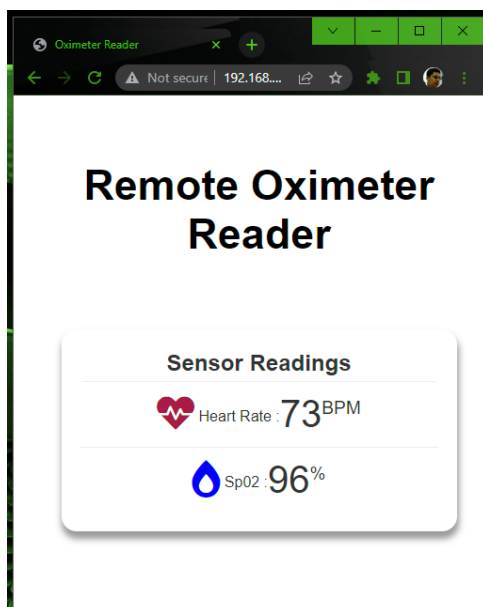
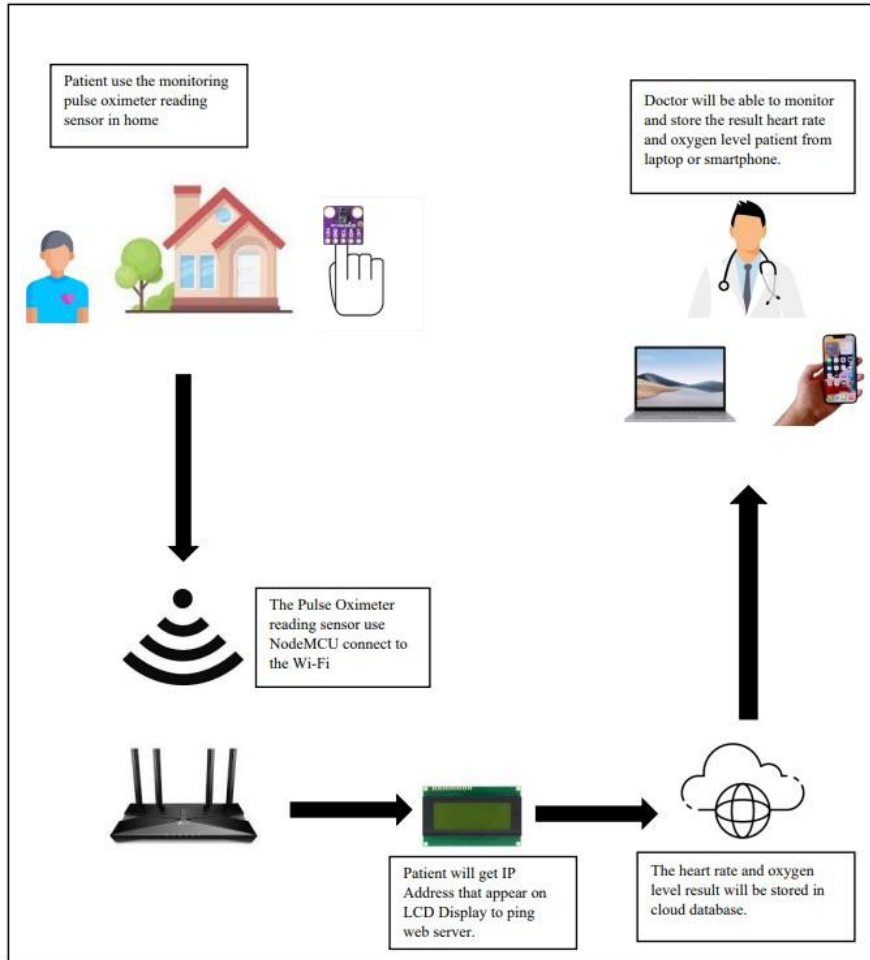

**Figure 4:** Display Dashboard of the Remote Oximeter Reader on PC (Personal Computer) and Mobile Device.

## Testing Design Scenario



Figure 5 shows the design scenario for the testing phase. In this scenario, the user will use the monitoring pulse oximeter reading sensor from the remote and isolated area due to the quarantined cause. The user will connect the microcontroller NodeMCU with Wi-Fi network connection, get the web server's IP address, and see the result for heart rate and oxygen level at the LCD display. The result will be stored in a cloud database, and the medical authorities will be able to monitor the patient's heart rate and oxygen level every day, at any time and any place.



**Figure 5:** Design Scenario for monitoring pulse oximeter reading sensor using Wi-Fi based network architecture.

## FINDINGS AND DISCUSSIONS

The system was evaluated by testing the prototype's sensitivity. This testing was conducted to see the accurate output from the prototype through the LCD, and the result was sent to the Webserver of ESP8266 MAX30100 Pulse Oximeter. The prototype sends the pulse rate and oxygen level results when the user puts their finger on the sensor. The LCD would display the pulse rate and the oxygen level. Five candidates participated to evaluate this test. Each of them tested the Pulse Oximeter prototype and compared the reading with the original Pulse Oximeter 10 times.

Table 1 showed the Pulse Oximeter monitoring system sensitivity test result. It shows that LCD and Webserver have displayed a real-time reading from the Pulse Oximeter sensor. The result also showed that the MAX30100 Pulse Oximeter sensor is accurate. The comparison testing also shows that the proposed device reading value of the heart rate (BPM) only gives an average of 6 BPM difference compared to the conventional oximeter reader. The SPO2 reading results also indicate that the proposed device gives only an average of 0.5% difference compared to the results from the conventional oximeter reader.

**Table 1:** MAX30100 Pulse Oximeter Sensor Sensitivity Test result

No	Name	Tested finger	Accuracy	Value Heart Rate (BPM) (Prototype Pulse Oximeter)	Value Heart Rate (BPM) (Conventional Pulse Oximeter)	Difference BPM reading	SPO2 reading (%) (Prototype Pulse Oximeter)	SPO2 reading (%) (conventional Pulse Oximeter)	Diff. % SPO2 reading (%)
1	USER 1	Thumb Finger	accurate	72	79	7	98%	98%	0%
2	USER 2	Index Finger	accurate	78	76	2	97%	98%	1%
3	USER 3	Middle Finger	accurate	79	76	3	97%	98%	1%
4	USER 4	Ring Finger	accurate	80	78	8	98%	98%	0%
5	USER 5	Little Finger	accurate	83	73	10	98%	98%	0%



Table 2 shows the network testing results for the pulse oximeter monitoring system. There are three users to test this prototype, Primary User (PU1), Secondary User one (SU1), and Secondary User two (SU2). All users have used the Pulse Oximeter Reading system separately, starting with PU1, SU1 and finally SU2. This test aims to check the network and duration of time taken from Pulse Oximeter MAX30100 to send pulse rate, and oxygen level (SpO2) result from NodeMCU ESP8266 to LCD (Liquid Crystal Display) Display 20x4 and Web Server. Table 5.3 shows this test's activation time, uplink, downlink, and end-to-end delay. The results have concluded that the system only took an average of 5.6 seconds of end-to-end delay to complete the data transmission activity.

**Table 2:** Pulse Oximeter reading network testing result

Time Slot	1	2	3	4	5	Average (s)
<b>Primary User (PU1)</b>						
Activation time	01:57:05	01:57:10	01:57:21	01:57:32	01:57:42	
Uplink time	01:57:15	01:57:20	01:57:30	01:57:40	01:58:51	
Downlink time	01:57:10	01:57:15	01:57:27	01:57:37	01:57:48	
End-to-end delay (s)	5	5	6	5	6	5.4
<b>Secondary User (SU1)</b>						
Activation time	02:57:11	02:57:22	02:57:32	02:57:43	02:57:53	
Uplink time	02:57:20	02:57:30	02:57:41	02:57:51	02:57:02	
Downlink time	02:57:17	02:57:27	02:57:38	02:57:48	02:57:59	
End-to-end delay (s)	6	5	6	5	6	5.6
<b>Secondary User (SU2)</b>						
Activation time	02:57:27	02:57:38	02:57:48	02:57:59	02:57:10	
Uplink time	02:57:36	02:57:47	02:57:57	02:57:08	02:57:18	
Downlink time	02:57:33	02:57:44	02:57:54	02:57:05	02:57:15	
End-to-end delay (s)	6	6	6	6	5	5.8

Figure 6. summarized respondent feedback regarding the Pulse Oximeter Reading system's overall performance for usability testing. Most respondents chose either 'Strongly Agree' (30.4%) or 'Agree'





(60.9%). This shows that the system was beneficial for monitoring Heart Rate and Oxygen level people's conditions in the community.

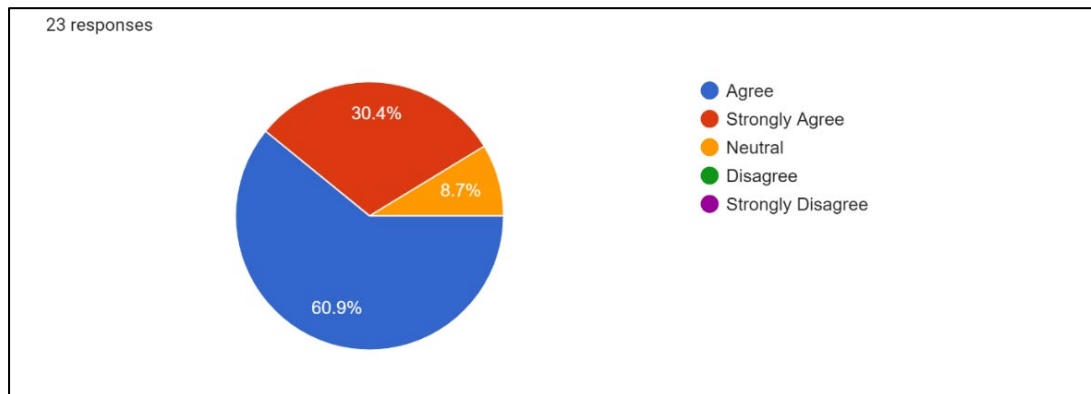

**Figure 6:** Pie Chart of user's response in terms of practicality of the system.

## CONCLUSION AND RECOMMENDATIONS

The prototype system had successfully passed all the testing that had been conducted. The project was a success and met all the project's objectives. The first objective was to develop an alternative option to remotely monitor Covid-19 patients in recording their oxygen levels using an oximeter reader connected with the Web Server using private hosting. The prototype developed in this project functioned well as a real-time air Pulse Oximeter system. The LCD Display will accurately display the pulse rate and Oxygen level (SpO2) result. The second objective was to implement performance testing regarding a proposed system in accuracy, network, and usability testing. Evaluate functional and prototype testing results on the Pulse Oximeter monitoring system that measured standard and limit values. Network testing was also conducted to ensure the connectivity rate from NodeMCU ESP8266 with the Web Server of PMA30100 Pulse Oximeter, which showed a positive result. Finally, the MAX30100 Pulse Oximeter sensitivity test was conducted to determine the sensor's accuracy for various finger types. This study has tested pulse reading with a different finger, including the thumb finger, index finger, middle finger, ring finger and little finger. This system can be improved for future work by running it in an actual medical practice environment for much better data collection for a more accurate medical diagnosis of Covid-19 symptoms.

## ACKNOWLEDGMENTS

The authors express their gratitude to the colleagues and research team members for their collaboration and discussions, which have improved methodologies presented in this work.

## CONFLICT OF INTERESTS DECLARATION

The authors declare no conflict of interests regarding the publication of this article.



## REFERENCES

- Dhont, S., Derom, E., Van Braeckel, E., Depuydt, P., & Lambrecht, B. N. (2020). The pathophysiology of 'happy' hypoxemia in COVID-19. *Respiratory research*, 21(1), 198. <https://doi.org/10.1186/s12931-020-01462-5>
- Jayasingh, R., David, J., Joel Morris Raaj, M., Daniel, D., & Blessytelagathoti, D. (2020). IoT Based Patient Monitoring System Using NodeMCU. *ICDCS 2020 - 2020 5th International Conference on Devices, Circuits and Systems*, 240–243. <https://doi.org/10.1109/ICDCS48716.2020.243588>
- Kadhim, K. T., Alsahlany, A. M., Wadi, S. M., & Kadhum, H. T. (2020). Monitor human vital signs based on IoT technology using MQTT protocol. *AIP Conference Proceedings*, 2290(December). <https://doi.org/10.1063/5.0027363>
- Lee, K. C., Morgan, A. U., Chaiyachati, K. H., Asch, D. A., Xiong, R. A., Do, D., Kilaru, A. S., Lam, D., Parambath, A., Friedman, A. B., Meisel, Z. F., Snider, C. K., Chisholm, D. L., Kelly, S., Hemmons, J. E., Abdel-Rahman, D., Ebert, J., Ghosh, M., Reilly, J., O'Malley, C. J., Delgado, M. K. (2022). Pulse Oximetry for Monitoring Patients with Covid-19 at Home - A Pragmatic, Randomized Trial. *The New England journal of medicine*, 386(19), 1857–1859. <https://doi.org/10.1056/NEJMc2201541>
- Marathe, S., Zeeshan, D., Thomas, T., & Vidhya, S. (2019). A Wireless Patient Monitoring System using Integrated ECG module, Pulse Oximeter, Blood Pressure and Temperature Sensor. *Proceedings - International Conference on Vision Towards Emerging Trends in Communication and Networking, ViTECoN 2019*, 1–4. <https://doi.org/10.1109/ViTECoN.2019.8899541>
- Malasinghe, L. P., Ramzan, N., & Dahal, K. (2019). Remote patient monitoring: a comprehensive study. *Journal of Ambient Intelligence and Humanized Computing*, 10(1), 57–76. <https://doi.org/10.1007/s12652-017-0598-x>
- Patil, C., & Chaware, A. (2021). Heart (Pulse Rate) Monitoring using Pulse Rate Sensor, Piezo Electric Sensor and NodeMCU. 8th International Conference on Computing for Sustainable Global Development (INDIACom). pp. 337-340.
- Patil, C., & Chaware, A. (2021). Integration of Internet of Things, Cloud Computing. In *IOP Conference Series: Materials Science and Engineering* (Vol. 1022, No. 1, p. 012099). IOP Publishing.
- Pronovost, P. J., Cole, M. D., & Hughes, R. M. (2022). Remote Patient Monitoring During COVID-19: An Unexpected Patient Safety Benefit. *JAMA*, 327(12), 1125–1126. <https://doi.org/10.1001/jama.2022.2040>

